



L I V I N G  
S P A C C E

# **PREDSTAVITVENI KATALOG**

[www.livingspacce.si](http://www.livingspacce.si)

[info@livingspacce.si](mailto:info@livingspacce.si)

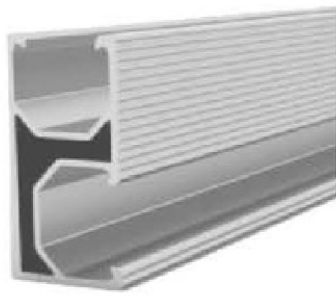

Roof Rail A

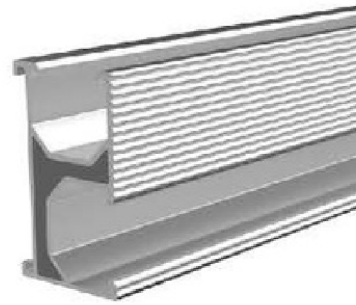

Roof Rail A2



Roof Rail B

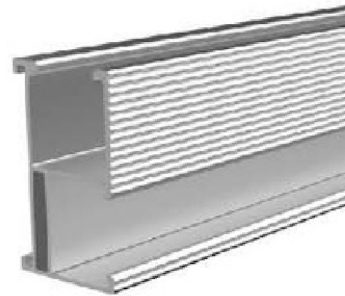

Roof Rail B2

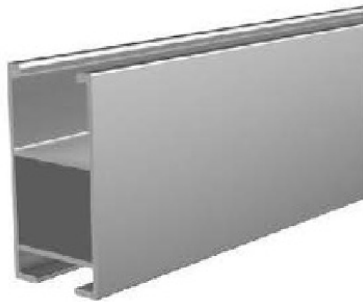

Roof Rail C

Roof Rail A、A2 maximum wind speed design standard(mm)

Module length \ Span	800	1000	1200	1400	1600	1800	2000
≤1800	60m/s	60m/s	50m/s	42m/s	35m/s	30m/s	26m/s
≤2300	60m/s	50m/s	42m/s	35m/s	30m/s	26m/s	22m/s

Roof Rail B、B2 maximum wind speed design standard(mm)

Module length \ Span	800	1000	1200	1400	1600	1800	2000
≤1800	60m/s	56m/s	45m/s	38m/s	32m/s	27m/s	23m/s
≤2300	60m/s	47m/s	38m/s	32m/s	27m/s	23m/s	20m/s

Roof Rail C maximum wind speed design standard(mm)

Module length \ Span	800	1000	1200	1400	1600	1800	2000
≤1800	60m/s	53m/s	43m/s	36m/s	30m/s	26m/s	22m/s
≤2300	57m/s	45m/s	36m/s	30m/s	26m/s	22m/s	19m/s